



EASY BELT EXCHANGE

Both shroud covers are made of stainless steel and are simply opened backwards. This allows free access to the individual belts.

Rotate the front tension wheel to loosen the belt which can then be removed from the side.

Similarly, by rotating the adjustment wheel, the new belt can be centred onto the middle of the working surface.



JADE 700

The JADE 700 is a stable wet double-belt grinder for deburring and pre-grinding of samples or other materials.

It is possible to use belts with 2 different grain sizes simultaneously.



DRIVE

A powerful motor drives both belts at the same time. The rubber coated drive wheels, which are fitted with a special tread, prevent the belt from slipping.

WATER-COOLING

A water film is created over the whole width of the front end of the belt. Waste material generated is carried to the back with the water and both are drained-off into the machine. Drain-offs are separated, one to the left, one to the right.

BASIC MODULE



JADE 700



Order No.: M6000010

- » two grinding belts
- » water cooling
- » manual belt centering
- » water regulating valve left/right
- » aluminium design, powder coated
- » stainless steel cover

EQUIPMENT



POWER SUPPLY

Equipment 1

400 V/50 Hz (3Ph/N/PE)

Order No.: A6000001

Equipment 2

480 V/60 Hz (3Ph/PE)

Order No.: A6000002

Equipment 3

220 V/60 Hz (3Ph/PE)

Order No.: A6000003

ACCESSORIES



SETTLING TANK



» 2-chamber-compartment, 45 ltr.

for System lab cabinet
(insertion mechanism)

referring height of System cabinet

H 800 mm Order No.: A5810261

H 900 mm Order No.: A5810237

» inlet sieve and filter bag

mobile



Order No.: A5800496

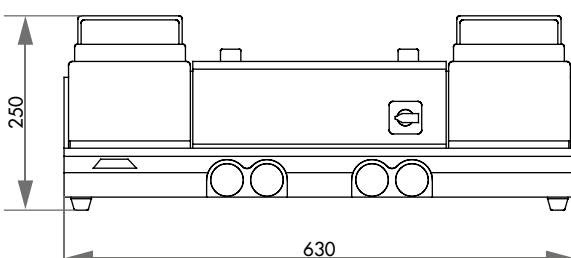
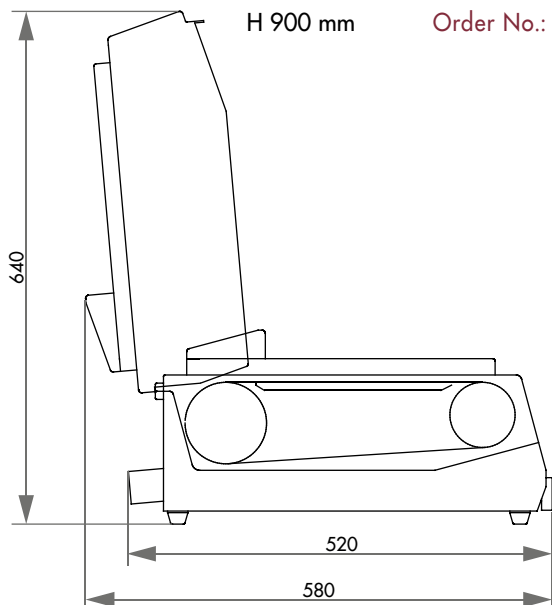

CONNECTION SET



Order No.: Z5600008

1 drain tube	Ø 40 mm; 1.5 m
1 pressure tube	R 1/2"; 2 m

SPECIFICATIONS

Connected load	1.4 kVA
Belt speed	7 m/sec.
Grinding belts	100 x 920 mm 100 x 915 mm
Water connection	drain 1 x R1/2" valve right and left, each Ø 40mm
WxHxD ~	630 x 250 x 520 mm
Weight	55 kg